

Installing EDT bearings in high temperature locations

Heated locations like dryers, ovens and fryers are very common in many industries as food is cooked, bulk chemicals dried, fiber glass baked, and heat-treated metal parts quenched, etc. In high temperature applications, the expansion of different materials relative to each other causes design difficulties and must be addressed in the bearings that allow these heated devices to move.

Materials expand with increasing levels of temperature and things that are fixed at both ends of an expanding material will break. It is for this reason that expansion bearings came about. EDT's plane bearings work very well in high temperature conditions with a fixed bearing on the drive side of a device and an expanding bearing on the opposite side (see Fig 14-1).

Bearing installation in high temperature locations

The fixed bearing should be an EDT Poly-Round® out of a high temperature material in a metal housing with a locking sleeve flange on one side of the bearing and a split set collar on the opposite side of the same bearing. This allows control of the lateral movement of the shaft to be contained by just the one bearing. The opposite expansion bearing should be a Poly-Round® out of high temperature material in a metal housing with locking sleeve that has an extended length body. The locking sleeve fixed to the shaft now has a longer journal to accommodate the float of the shaft as the temperature increases and decreases. The flange of the locking sleeve of the expansion bearing must be on the outboard side of the oven (see diagram). (Call EDT if space limitations require inside mount.)

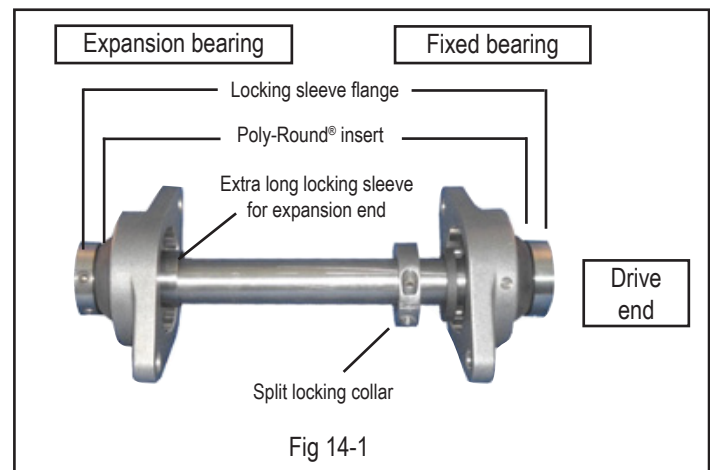

With few exceptions, lubricants of all kinds should not be applied in hot applications.

Food grade high temp materials

Fryer bearings associated with food processing must, in most cases, be approved as a "food ingredient." EDT's FA bearing material makes the grade for temperature (operates to 500°F), for USDA/FDA criteria and for ease-of-maintenance. As with all other high-temperature applications, this must be in a Poly-Round® style (see Fig 14-2).



High speed or tension locations

High temperature locations with high speed or tension (flat belt take-ups, pumps, fans operating above 300°F ambient temperature) will be well served with high temperature, solid lubricated ball bearings. Operating temperature must be specified, and stainless, standard or "special material" bearings are all available options.

Threads

Since continuous expansion and contraction of metals will cause threaded products to vibrate loose, it is necessary to use an appropriate threadlocker on all setscrews.