



ALL-ROUND[®] STAINLESS STEEL BEARINGS



*All-Round[®]
Insert Bearings*



*All-Round[®]
ER Bearings*



Stainless/polymer plane bearings for use in high PV locations or areas where the application air temperature is lower than the bearing operating temperature, and where a Poly-Round[®] bearing is not best suited

All-Round[®] plane bearings

- Interchange with industry standard bearings
- All inch and metric sizes
- 316 ss locking sleeve for maximum toughness
- Stainless components are one time purchase. Under normal operating conditions only flanged polymer requires replacement
- Require no lubrication
- Sanitary
- Corrosion resistant
- Predictable replacement schedule

Advantages of All-Round[®] bearings over other style plane bearings

- Higher load capacity in radial and thrust applications
- Dissipates heat better than Poly-Round[®] bearings in applications where the air temperature is lower than the core of the bearing, and PV rating is critical

For more information on All-Round[®] bearings mounted in housings, see Section B (Ultimate Solution[®]) and Section C (All-Round[®] Solution)



Ultimate Solution[®]



All-Round[®] Solution

ALL-ROUND® BEARINGS

Solve Your Toughest Bearing and Shaft Problems

SPHERICAL SERIES



ER SERIES

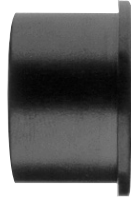

INSERTS

All-Round® stainless steel inserts with replaceable polymer bearings are:

- Maintenance free
- Compatible with industry standard insert sizes
- Corrosion resistant
- Cost effective
- Sanitary
- Predictable for operation and wear
- Long-term investments
- Ideal where lubrication is difficult to maintain

Under normal operating conditions, this unit is a one-time purchase and does not require replacement with typical bearing usage.

POLYMER BEARINGS

All-Round® polymer bearings are thin-walled, flanged plane bearings for use with **All-Round®** stainless inserts.

They can also be used separately as bearing replacements in idler gears and sprockets and in other stand-alone applications.

A variety of bearing materials are available to suit different applications.

See Material Selection Chart, page F-3.

EDT's QB material can be used in 90% of All-Round® applications. QB polymer is:

- Versatile
- High performing
- Extreme temperature resistant
- Cost effective
- USDA meat and poultry accepted (incidental)
- USDA dairy accepted (incidental)
- Completely void of animal fats for Kosher certified processing

NOTE: In submerged locations, QF polymer is recommended.

LOCKING SLEEVES

Purposes:

- Repair damaged shafts
- Extend bearing life
- Eliminate shaft damage from plane bearing wear
- Control lateral shaft movement within the bearing

Features:

- 316 SS for maximum wear and corrosion resistance
- Optional hardened materials available for extreme abrasion applications
- Available in a range of standard lengths and custom sizes

DoubleLock® sleeves have twice the grip and staying power of setscrew locking sleeves.

Locking sleeves can be used with **all** EDT bearing products.

See Polymer Block Bearings Section G (GREEN) and Poly-Round® Bearings Section H (WHITE).

Applications not suitable for plane bearings (see Section K for substitution)

- High tension applications (V-belt drives, flat belt conveyors, urethane belts)
- High speed devices (fans, pumps, table-top conveyors)
- Overhung loads (shaft-mounted gear reducers)
- Trunnion applications

Use ball bearing instead of All-Round® or Poly-Round® bearing (see section K)

- In temperatures below 0°F / -18 C
- Repeat thermal cycles

Use Poly-Round® bearing instead of All-Round® (see section J)

Bearing capacity is measured by PV and will determine the amount of heat generated in a plane bearing. PV is the relationship of the load to the shaft speed in a bearing. Factors influencing PV limits (heat generation) include:

- Material selection
- Journal surface finish
- Bearing wall thickness
- Running clearance
- Proximity to moisture
- Ambient temperature
- Cycle time

HOW TO CALCULATE PV

PV - $P \times V$

P - pressure in PSI (lbs/sq in)

V - velocity in SFM (surface ft/min)

P - F/A

where F = force (load) on bearing

A = shaft dia (in) x LTB

(LTB = bearing length through the bore)

V - $.262 \times D \times \text{RPM}$

where D = shaft diameter (in)

RPM = shaft revolutions/min

ALL-ROUND® BEARINGS OFFER INSTALLATION VERSATILITY

All-Round® bearings can be mounted horizontally or vertically.

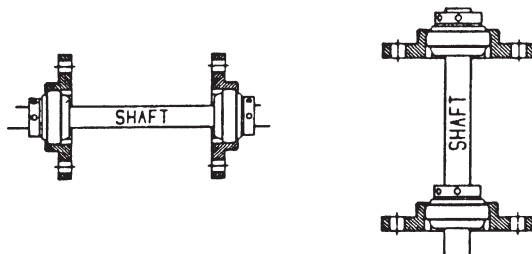

They can also be assembled in different ways to adjust the total length-thru-bore (LTB) of a mounted set.

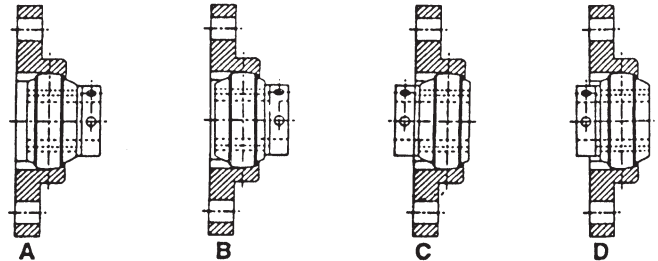

In any configuration, the locking sleeve collar must run against the flange of the polymer bearing to prevent metal-to-metal contact and heat buildup. *Full mounting and installation instructions for all EDT bearings are located in the User Handbook, Section U (PURPLE).*

Material Section Chart

	Poly-Round® Bearing Materials	PV Limit*	Maximum Speed V (SFM)	Maximum Loading P (PSI)	Continuous Operating Temp.	Performance in Moisture		ΔT Dimensional Stability with Temp Change	Chemical Resistance	Abrasion Resistance	Impact Resistance	USDA/FDA Contact Approval
						Washdown	Submerged					
Bearings	PA UHMW white	1,000	50	800	150°F	Excellent	Excellent	Poor	Excellent	Abrasion applications are very non-predictable. Each application must be tested for abrasion resistance.	Excellent	Direct
	NA gray	6,000	350	2,000	200°F	Excellent	Good	Fair	Good		Excellent	Incidental
	QB black-green	50,000	400	3,000	550°F	Excellent	Poor	Excellent	Fair		Fair	Incidental
	QF black	60,000	400	6,000	450°F	Excellent	Excellent	Excellent	Excellent		Fair	Incidental
	MY	20,000	100		1,000°F	Fair	Fair	Excellent	Fair		Good	No

* PV limits are shown for unlubricated radial bearing applications. Low temperature or submerged installation may permit PV limits up to 2x higher.

ALL-ROUND® ER BEARING ASSEMBLY

Stainless / Polymer Type ER Bearings – Setscrew Locking Sleeve

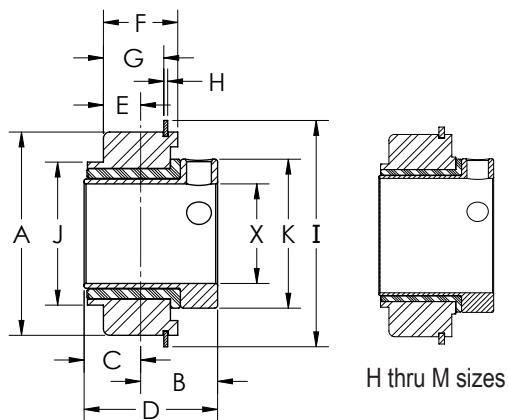

All sizes include non-corrosive snap ring.
204 & 205 stainless steel; other sizes nickel-plated.
Interchanges with industry-standard ER bearings.
All components are available separately.
See following pages this section.

B thru G sizes

H thru M sizes

-X = Setscrew locking sleeve; -x-LC = DoubleLock® locking sleeve

"QB" indicates one bearing material; other materials available (see page F-3).

ER Equivalent Interchange	PART # Group in —OD— Ring mm	x= Shaft Diameter	A	B	C	D	E	F	G	H	I	J	K	P	M	Wt
			v	in mm	in mm	in mm	in mm	in mm	in mm	in mm	in mm	in mm	in mm	in mm	Replacement Polymer Flanged Bearing Part #	Locking Sleeve Part #
ER-8 ER-9 ER-10 ER-11 ER-12 ER-204	QBEB9-x B 204	1/2 9/16 5/8 11/16 3/4 20 mm	1.85 47	.72 18.3	.5 12.7	1.22 31.0	.32 8.0	.63 16.0	.49 12.5	.04 1.1	2.08 52.7	1.25 31.8	1.25 31.8	QBCUBO-B	ZAMUB6-x	.4
ER-13 ER-14 ER-15 ER-16 ER-205	QBEC9-x C 205	13/16 7/8 15/16 1 25 mm	2.047 52	.77 19.7	.56 14.3	1.33 33.7	.37 9.5	.75 18.0	.61 15.5	.04 1.1	2.28 57.9	1.4 36.5	1.5 38.1	QBCUCO-C	ZAMUC6-x	.6
ER-17 ER-18 ER-19 ER-205 ER-206	QBED9-x D 206	1-1/16 1-1/8 1-3/16 1-1/4 30 mm	2.44 62	.88 22.2	.63 15.9	1.50 38.1	.43 11.0	.88 22.2	.68 17.3	.07 1.7	2.67 67.7	1.69 41.3	1.75 44.5	QBCUDO-D	ZAMUD6-x	1.0
ER-20 ER-21 ER-22 ER-23 ER-207	QBEUE9-x E 207	1-1/4 1-5/16 1-3/8 1-7/16 35 mm	2.835 72	1 25.4	.69 17.5	1.69 42.9	.47 12.0	.95 24.0	.75 19.1	.07 1.7	3.09 78.8	1.94 49.2	2 50.8	QBCUEO-E	ZAMUE6-x	1.8
ER-24 ER-25 ER-208	QBEUF9-x F 208	1-1/2 1-9/16 40 mm	3.15 80	1.12 30.2	.75 19.1	1.94 49.2	.55 14.0	1.10 28.0	.91 23.0	.07 1.7	3.41 86.6	2.13 54.0	2.25 57.2	QBCUFO-F	ZAMUF6-x	2.3
ER-26 ER-27 ER-28 ER-209	QBEUG9-x G 209	1-5/8 1-11/16 1-3/4 45 mm	3.35 85	1.12 30.2	.75 19.1	1.94 49.2	.55 14.0	1.10 28.0	.91 23.1	.07 1.7	3.61 91.6	2.27 57.5	2.50 63.5	QBCUGO-G	ZAMUG6-x	2.5
ER-30 ER-31 ER-210	QBEUH9-x H 210	1-7/8 1-15/16 50 mm	3.54 90	1.28 32.6	.75 19.1	2.03 51.6	.55 14.0	1.10 28.0	.88 22.3	.10 2.5	3.80 96.5	2.50 63.5	2.69 68.3	QBCUHO-H	ZAMUH6-x	2.5
ER-32 ER-34 ER-35 ER-211	QBEUI9-x I 211	2 2-1/8 2-3/16 55 mm	3.97 100	1.31 33.4	.88 22.2	2.19 55.5	.59 15.0	1.18 30.0	.96 24.3	.01 2.5	4.19 106.5	2.88 73.0	2.88 73.0	QBCUIO-I	ZAMUI6-x	3.5
ER-36 ER-38 ER-39 ER-212	QFEUJ9-x J 212	2-1/4 2-3/8 2-7/16 60 mm	4.33 110	1.56 39.7	1 25.4	2.56 65.1	.63 16.0	1.26 32.0	1.04 26.4	.10 2.5	4.59 116.6	3 76.2	3 76.2	QFCUJO-J	ZAMUJ6-x	4.8
ER-40 ER-43 ER-214	QFEUK9-x K 214	2-1/2 2-11/16 70 mm	4.92 125	1.63 41.3	1.13 28.6	2.75 69.9	.69 17.5	1.38 34.9	1.14 28.9	.11 2.8	5.30 134.7	3.34 85.7	4 101.6	QFCUKO-K	ZAMUK6-x	7.3
ER-46 ER-47 ER-215	QFEUL9-x L 215	2-7/8 2-15/16 75 mm	5.12 130	1.75 44.5	1.17 29.8	2.92 74.2	.75 19.1	1.50 38.1	1.26 32.1	.11 2.8	5.50 139.7	3.75 95.2	4 101.6	QFCULO-L	ZAMUL6-x	7.3

ALL-ROUND® ER BEARING ASSEMBLY

Stainless / Polymer Type ER Bearings – DoubleLock® Sleeve

All sizes include non-corrosive snap ring.
204 & 205 stainless steel; other sizes nickel-plated.
Interchanges with industry-standard ER bearings.
All components are available separately.
See following pages this section.

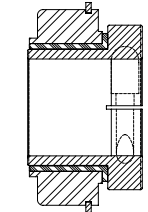
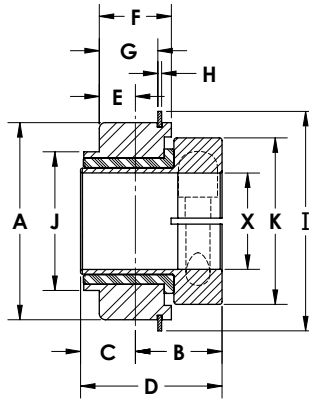

H thru M sizes

B thru G sizes

-X = Setscrew locking sleeve; -x-LC = DoubleLock® locking sleeve

"QB" indicates one bearing material; other materials available (see page F-3).

ER Equivalent Interchange	PART # Group Ring in —OD— mm	x= Shaft Diameter	A	B	C	D	E	F	G	H	I	J	K	Replacement Polymer Flanged Bearing Part #	DoubleLock® Part #	Wt lbs
			in mm	in mm	in mm	in mm	in mm	in mm	in mm	in mm	in mm	in mm	in mm			
ER-8 ER-9 ER-10 ER-11 ER-12 ER-204	QBEUB9-x-LC B 204	1/2 9/16 5/8 11/16 3/4 20 mm	1.85 47	.88 22.3	.5 12.7	1.38 35.0	.32 8.0	.63 16.0	.49 12.5	.04 1.1	2.08 52.7	1.25 31.8	1.63 40	QBCUBO-B	ZAMUB6-x-LC	.45
ER-13 ER-14 ER-15 ER-16 ER-205	QBEUC9-x-LC C 205	13/16 7/8 15/16 1 25 mm	2.047 52	.9 22.8	.56 14.3	1.46 37.0	.37 9.5	.75 18.0	.61 15.5	.04 1.1	2.28 57.9	1.4 36.5	1.75 43	QBCUCO-C	ZAMUC6-x-LC	.61
ER-17 ER-18 ER-19 ER-20S ER-206	QBEUD9-x-LC D 206	1-1/16 1-1/8 1-3/16 1-1/4 30 mm	2.44 62	.9 22.8	.63 15.9	1.52 38.1	.43 11.0	.88 22.2	.68 17.3	.07 1.7	2.67 67.7	1.69 41.3	2.0 49	QBCUDO-D	ZAMUD6-x-LC	.97
ER-20 ER-21 ER-22 ER-23 ER-207	QBEUE9-x-LC E 207	1-1/4 1-5/16 1-3/8 1-7/16 35 mm	2.835 72	1.0 25.4	.69 17.5	1.69 42.9	.47 12.0	.95 24.0	.75 19.1	.07 1.7	3.09 78.8	1.94 49.2	2.25 55	QBCUEO-E	ZAMUE6-x-LC	1.8
ER-24 ER-25 ER-208	QBEUF9-x-LC F 208	1-1/2 1-9/16 40 mm	3.15 80	1.18 29.9	.75 19.1	1.16 29.4	.55 14.0	1.10 28.0	.91 23.0	.07 1.7	3.41 86.6	2.13 54.0	2.38 58	QBCUFO-F	ZAMUF6-x-LC	2.3
ER-26 ER-27 ER-28 ER-209	QBEUG9-x-LC G 209	1-5/8 1-11/16 1-3/4 45 mm	3.35 85	1.18 29.9	.75 19.1	1.16 29.4	.55 14.0	1.10 28.0	.91 23.1	.07 1.7	3.61 91.6	2.27 57.5	2.75 67	QBCUGO-G	ZAMUG6-x-LC	2.5
ER-30 ER-31 ER-210	QBEUH9-x-LC H 210	1-7/8 1-15/16 50 mm	3.54 90	1.34 34.0	.75 19.1	2.09 53.0	.55 14.0	1.10 28.0	.88 22.3	.10 2.5	3.80 96.5	2.50 63.5	3.0 74	QBCUHO-H	ZAMUH6-x-LC	2.7
ER-32 ER-34 ER-35 ER-211	QBEUI9-x-LC I 211	2 2-1/8 2-3/16 55 mm	3.97 100	1.37 34.8	.88 22.2	2.25 57.1	.59 15.0	1.18 30.0	.96 24.3	.01 2.5	4.19 106.5	2.88 73.0	3.25 80	QBCUIO-I	ZAMUI6-x-LC	3.8
ER-36 ER-38 ER-39 ER-212	QFEUJ9-x-LC J 212	2-1/4 2-3/8 2-7/16 60 mm	4.33 110	1.62 41.1	1 25.4	2.62 66.5	.63 16.0	1.26 32.0	1.04 26.4	.10 2.5	4.59 116.6	3 76.2	3.4 83	QFCUJO-J	ZAMUJ6-x-LC	5.0
ER-40 ER-43 ER-214	QFEUK9-x-LC K 214	2-1/2 2-11/16 70 mm	4.92 125	1.63 41.3	1.13 28.6	2.75 69.9	.69 17.5	1.38 34.9	1.14 28.9	.11 2.8	5.30 134.7	3.34 85.7	3.8 93	QFCUKO-K	ZAMUK6-x-LC	6.9
ER-46 ER-47 ER-215	QFEUL9-x-LC L 215	2-7/8 2-15/16 75 mm	5.12 130	1.75 44.5	1.17 29.8	2.92 74.2	.75 19.1	1.50 38.1	1.26 32.1	.11 2.8	5.50 139.7	3.75 95.2	4.13 101	QFCULO-L	ZAMUL6-x-LC	7.3



ALL-ROUND® CYLINDRICAL INSERTS FOR ER SERIES

304 stainless steel (316 ss or other materials optional)

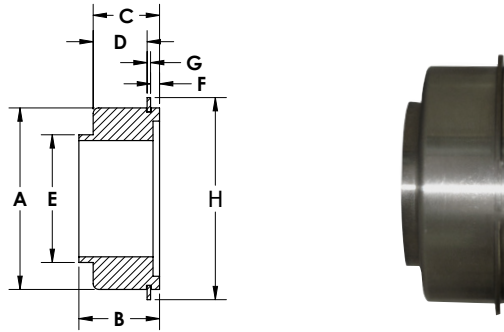

ALL-ROUND® spherical insert requires ALL-ROUND® flanged polymer bearing for operation. See pages F-2 and F-3.

PART # Group	Ring	Insert accommodates the following shaft sizes		v in mm	B in mm	C in mm	D in mm	E in mm	F in mm	G in mm	H in mm	Wt lbs
		mm	in									
ZAEUBO			1/2 9/16 5/8 11/16 3/4 13/16	1.850 47	1/2 12.7	15/16 23.8	.492 12.5	1-1/4 31.8	.09 2.4	.044 1.1	2.075 52.7	.3
ZAEUCO			13/16 7/8 15/16 1	2.047 52	9/16 14.3	1 25.4	.610 15.5	1-7/16 36.5	.09 2.4	.044 1.1	2.280 57.0	.40
ZAEUDO			1 1-1/16 1-1/8 1-3/16 1-1/4	2.441 62	45/64 17.9	1-3/16 30.2	.683 17.3	1-11/16 41.3	.13 3.2	.067 1.7	2.665 67.7	.7
ZAEUEO			1-3/16 1-1/4 1-5/16 1-3/8 1-7/16	2.835 72	7/8 22.2	1-3/8 34.9	.753 19.1	1-61/64 49.5	.13 3.2	.067 1.7	3.094 78.6	1.0
ZAEUFO			1-7/16 1-1/2 1-9/16 1-5/8	3.150 80	29/32 22.9	1-1/2 38.1	.910 23.1	2-1/8 54.0	.13 3.2	.067 1.7	3.409 86.6	1.5
ZAEUGO			1-1/2 1-5/8 1-11/16 1-3/4	3.346 85	31/32 24.6	1-9/16 39.7	.910 23.1	2-17/64 57.4	.13 3.2	.067 1.7	3.606 91.6	1.7
ZAEUHO			1-11/16 1-3/4 1-13/16 1-7/8 1-15/16 2	3.543 90	31/32 24.6	1-9/16 39.7	.880 22.4	2-1/2 63.5	.13 3.2	.097 2.5	3.799 96.5	1.8
ZAEUIO			1-15/16 2 2-1/16 2-1/8 2-3/16 2-1/4	3.937 100	1-1/8 28.6	1-3/4 44.5	.959 24.4	2-7/8 73.0	.13 3.2	.097 2.5	4.193 106.5	2.7
ZAEUJO			2-3/16 2-1/4 2-5/16 2-3/8 2-7/16	4.331 110	1-11/32 34.1	2 50.8	1.038 26.4	3 76.2	.13 3.2	.097 2.5	4.591 116.6	3.9
ZAEUKO			2-7/16 2-1/2 2-5/8 2-11/16 2-3/4	4.921 125	1-1/4 31.8	2 50.8	1.139 28.9	3-3/8 85.7	.13 3.2	.111 2.8	5.303 134.7	5.3
ZAEULO			2-11/16 2-3/4 2-13/16 2-7/8 2-15/16 3	5.118 130	1-3/16 30.2	2 50.8	1.264 32.1	3-3/4 95.2	.13 3.2	.111 2.8	5.500 139.7	5.8
ZAEUMO			2-15/16 3 3-1/8 3-3/16	5.511 140	1-13/32 35.7	2-1/4 57.2	1.389 35.3	4 101.6	.19 4.8	.111 2.8	5.894 149.7	7.2



ER

Standard

-04
(extra length for heat expansion)

ALL-ROUND® SETSCREW LOCKING SLEEVES

Standard and ER Series - 316 stainless steel

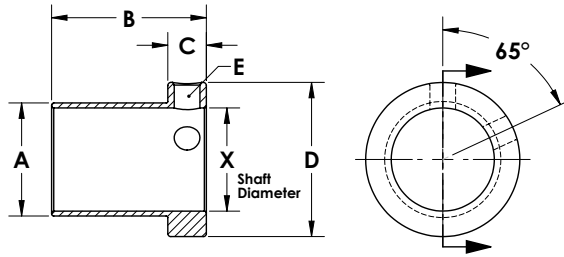

Threadlocker should always be used with setscrews on locking sleeves.

Other sizes and materials are available on a custom basis.

x = Shaft Diameter		LOCKING SLEEVE STANDARD LENGTH		STANDARD B	LOCKING SLEEVE ER LENGTH		ER B	LOCKING SLEEVE -04 LENGTH		-04 B	A	C	D	2 ea ss set screw	Wt
mm	in	PART # Group Ring	in mm	PART # Group Ring	in mm	PART # Group Ring	in mm	PART # Group Ring	in mm	in mm	in mm	in mm	in mm		lbs
12 15 17	1/2 9/16 5/8 11/16	ZALUA6-x A (203)	1-11/32 34.2	ZAMUA6-x A (203)	1-7/64 28.2	ZALUA6-x-04 A (203)	1.92 49	25/32 20.0	3/8 9.5	1-1/8 28.6	1/4-28	.2			
12 15 17 20	1/2 9/16 5/8 11/16 3/4 13/16	ZALUB6-x B (204)	1-15/32 37.4	ZAMUB6-x B (204)	1-1/4 31.8	ZALUB6-x-04 B (204)	2.04 52	29/32 23.2	3/8 9.5	1-1/4 31.8	1/4-28	.2			
25	13/16 7/8 15/16 1	ZALUC6-x C (205)	1-17/32 39.0	ZAMUC6-x C (205)	1-3/8 34.8	ZALUC6-x-04 C (205)	2.11 55.5	1-3/32 27.9	3/8 9.5	1-1/2 38.1	1/4-28	.2			
		ZALUCH-1	1.89 48.0			2.11 55.5									
30	1 1-1/16 1-1/8 1-3/16 1-1/4	ZALUD6-x D (206)	1-53/64 46.4	ZAMUD6-x D (206)	1-35/64 39.1	ZALUD6-x-04 D (206)	2.12 53.8	1-11/32 34.3	31/64 11.9	1-3/4 44.5	3/8-24	.3			
35	1-3/16 1-1/4 1-5/16 1-3/8 1-7/16	ZALUE6-x E (207)	2-1/32 51.7	ZAMUE6-x E (207)	1-23/32 43.7	ZALUE6-x-04 E (207)	2.60 66.1	1-17/32 39.1	1/2 12.7	2 50.8	3/8-24	.6			
40	1-7/16 1-1/2 1-9/16 1-5/8	ZALUF6-x F (208)	2-7/32 56.4	ZAMUF6-x F (208)	1-31/32 50.0	ZALUF6-x-04 F (208)	2.79 70.8	1-23/32 43.8	9/16 14.3	2-1/4 57.2	3/8-24	.6			
45	1-1/2 1-5/8 1-11/16 1-3/4	ZALUG6-x G (209)	2-9/32 58.0	ZAMUG6-x G (209)	1-61/64 49.5	ZALUG6-x-04 G (209)	2.86 72.6	1-7/8 47.5	9/16 14.3	2-1/2 63.5	3/8-24	.9			
50	1-11/16 1-3/4 1-13/16 1-7/8 1-15/16 2	ZALUH6-x H (210)	2-9/32 58.0	ZAMUH6-x H (210)	2-3/64 51.9	ZALUH6-x-04 H (210)	2.86 72.6	2-3/32 53.3	9/16 14.3	2-11/16 68.3	3/8-24	1.0			
55	1-15/16 2 2-1/16 2-1/8 2-3/16 2-1/4	ZALUI6-x I (211)	2-15/32 62.8	ZAMUI6-x I (211)	2-13/64 55.9	ZALUI6-x-04 I (211)	3.04 77.2	2-11/32 59.7	9/16 14.3	2-7/8 73.0	3/8-24	1.3			
60	2-3/16 2-1/4 2-5/16 2-3/8 2-7/16	ZALUJ6-x J (212)	2-22/32 69.1	ZAMUJ6-x J (212)	2-37/64 65.3	ZALUJ6-x-04 J (212)	3.23 82	2-17/32 64.5	9/16 14.3	3 76.2	3/8-24	1.3			
70	2-7/16 2-1/2 2-5/8 2-11/16 2-3/4	ZALUK6-x K (214)	2-29/32 73.9	ZAMUJ6-x K (214)	2-49/64 70.1	ZALUK6-x-04 K (214)	3.48 88.4	2-27/32 72.4	3/4 19.1	4 101.6	1/2-20	3.0			
75	2-11/16 2-3/4 2-13/16 2-7/8 2-15/16 3	ZALUL6-x L (215)	2-29/32 73.9	ZAMUL6-x L (215)	2-29/32 73.9	ZALUL6-x-04 L (215)	3.48 88.4	3-9/64 79.8	3/4 19.1	4 101.6	1/2-20	2.2			
80	2-15/16 3 3-1/8 3-3/16	ZALUM6-x M (216)	3-5/32 80.3	ZALUM6-x M (216)	3-5/32 80.3	ZALUM6-x-04 M (216)	3.48 88.4	3-9/32 83.5	3/4 19.1	4-1/2 114.3	1/2-20	3.0			

ALL-ROUND® DOUBLELOCK® SLEEVES

Standard and ER Series - 316 stainless steel

ER



Standard



-04
(extra length for heat expansion)



Threadlocker should always be used with clamping screws on locking sleeves.

Other sizes and materials are available on a custom basis.

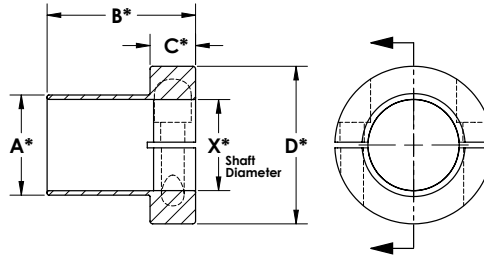

x= Shaft Diameter		DOUBLELOCK® STANDARD LENGTH		STD LENGTH B	DOUBLELOCK® ER LENGTH		ER B	DOUBLELOCK® -04 LENGTH		-04 B	A	C	D	2 ea SHCS	Wt
mm	in	PART #		in mm	PART #		in mm	PART #		in mm	in mm	in mm	in mm		lbs
		Group	Ring		Group	Ring		Group	Ring						
12 15 17	1/2 9/16 5/8 11/16	ZALUA6-x-LC		1.47 37	ZAMUA6-x-LC			ZALUA6-x-04-LC		2.07 52.6	0.78 20.0	.44 11	1.49 38	1/4-28	.2
		A	(203)		A	(203)		A	(203)						
12 15 17 20	1/2 9/16 5/8 3/4 13/16	ZALUB6-x-LC		1.56 39	ZAMUB6-x-LC		1.35 34	ZALUB6-x-04-LC		2.17 55.1	0.90 23.2	.50 13	1.63 41	1/4-28	.2
		B	(204)		B	(204)		B	(204)						
25	13/16 7/8 15/16 1	ZALUC6-x-LC		1.63 41	ZAMUC6-x-LC		1.47 37	ZALUC6-x-04-LC		2.23 56.6	1.09 27.9	.50 13	1.75 44	1/4-28	.2
		ZALUCH-1-LC		2.01 27.9				C	(205)						
		ZALUCH-1-LCHTV		1.60 41											
		C	(205)		C	(205)		C	(205)						
30	1 1-1/16 1-1/8 1-3/16 1-1/4	ZALUD6-x-LC		1.81 46	ZAMUD6-x-LC		1.54 39	ZALUD6-x-04-LC		2.42 61.5	1.34 34.3	.50 13	2.0 50	1/4-28	.4
		D	(206)		D	(206)		D	(206)						
35	1-3/16 1-1/4 1-5/16 1-3/8 1-7/16	ZALUE6-x-LC		2.00 51	ZAMUE6-x-LC		1.69 43	ZALUE6-x-04-LC		2.60 66	1.53 39.1	.50 13	2.25 57	1/4-28	.5
		E	(207)		E	(207)		E	(207)						
40	1-7/16 1-1/2 1-9/16 1-5/8	ZALUF6-x-LC		2.13 54	ZAMUF6-x-LC		1.88 48	ZALUF6-x-04-LC		2.73 69.3	1.71 43.8	.50 13	2.38 60	1/4-28	.6
		F	(208)		F	(208)		F	(208)						
45	1-1/2 1-5/8 1-11/16 1-3/4	ZALUG6-x-LC		2.31 58	ZAMUG6-x-LC		1.98 50	ZALUG6-x-04-LC		2.92 74.1	1.87 47.5	.63 16	2.75 70	5/16-24	.8
		G	(209)		G	(209)		G	(209)						
50	1-11/16 1-3/4 1-13/16 1-7/8 1-15/16 2	ZALUH6-x-LC		2.31 58	ZAMUH6-x-LC		2.08 53	ZALUH6-x-04-LC		2.92 74.1	2.09 53.3	.63 16	3.0 76	5/16-24	1.1
		H	(210)		H	(210)		H	(210)						
55	1-15/16 2 2-1/16 2-1/8 2-3/16 2-1/4	ZALUI6-x-LC		2.50 64	ZAMUI6-x-LC		2.24 57	ZALUI6-x-04-LC		3.11 79.0	2.34 59.7	.63 16	3.25 83	5/16-24	1.3
		I	(211)		I	(211)		I	(211)						
60	2-3/16 2-1/4 2-5/16 2-3/8 2-7/16	ZALUJ6-x-LC		2.74 70	ZAMUJ6-x-LC		2.60 66	ZALUJ6-x-04-LC		3.35 85.1	2.53 64.5	.63 16	3.4 86	5/16-24	1.4
		J	(212)		J	(212)		J	(212)						
70	2-7/16 2-1/2 2-5/8 2-11/16 2-3/4	ZALUK6-x-LC		2.88 73	ZAMUJ6-x-LC		2.73 69	ZALUJ6-x-04-LC		3.48 88.4	2.84 72.4	.75 19	3.8 96	3/8-24	2.0
		K	(214)		K	(214)		K	(214)						
75	2-11/16 2-3/4 2-13/16 2-7/8 2-15/16 3	ZALUL6-x-LC		2.88 73	ZAMUL6-x-LC		2.88 73	ZALUL6-x-04-LC		3.48 88.4	3.14 79.8	.75 19	4.13 105	3/8-24	2.0
		L	(215)		L	(215)		L	(215)						
80	2-15/16 3 3-1/8 3-3/16	ZALUM6-x-LC		3.16 80	ZAMUM6-x-LC			ZALUM6-x-04-LC		3.48 88.4	3.28 83.5	.75 19	4.7 120	3/8-24	2.0
		M	(216)		M	(216)		M	(216)						

ALL-ROUND® FLANGED POLYMER BEARINGS

Use with All-Round® inserts or as a sleeve bearing.

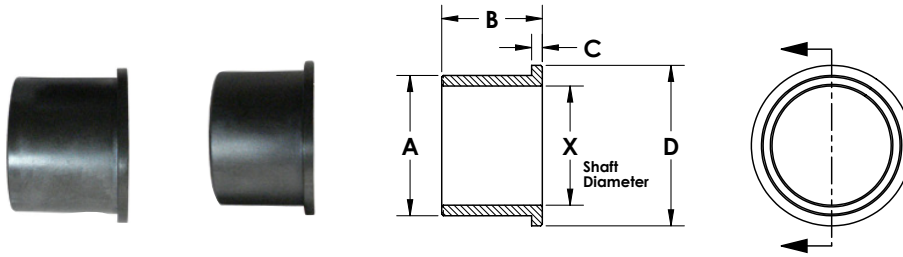

__ = Material Identifier (see selection chart on page F-3). QB is available in sizes A through I

STANDARD FLANGED BEARING		ER FLANGED BEARING		Insert accommodates the following shaft sizes		A	STANDARD B	ER B	C	D	Housing bore for press fit	Wt
PART #*		PART #*										
Group	Ring	Group	Ring	mm	in	in mm	in mm	in mm	in mm	in mm	in	lbs
__BUAO-A												
A	(203)			12 15 17	1/2 9/16 5/8 11/16	1 25.4	59/64 23.3		.10	1-1/8 28.6	.999	.01
__BUBO-B		__CUBO-B										
B	(204)	B	(204)	12 15 17 20	1/2 9/16 5/8 11/16 3/4 13/16	1-1/8 28.6	1-3/64 26.5	13/16 20.7	.10	1-1/4 31.8	1.126	.01
__BUCO-C		__CUCO-C										
C	(205)	C	(205)	25	13/16 7/8 15/16 1	1-5/16 33.3	1-7/64 28.1	15/16 23.9	.10	1-1/2 38.1	1.311	.02
__BUDO-D		__CUDO-D										
D	(206)	D	(206)	30	1 1-1/16 1-1/8 1-3/16 1-1/4	1-9/16 39.7	1-19/64 32.8	1-1/64 25.7	.10	1-3/4 44.5	1.561	.03
__BUEO-E		__CUEO-E										
E	(207)	E	(207)	35	1-3/16 1-1/4 1-5/16 1-3/8 1-7/16	1-3/4 44.5	1-31/64 37.6	1-5/32 29.4	.10	2 50.8	1.749	.04
__BUFO-F		__CUFO-F										
F	(208)	F	(208)	40	1-7/16 1-1/2 1-9/16 1-5/8	1-15/16 49.2	1-39/64 40.8	1-11/32 34.2	.10	2-1/4 57.2	1.936	.05
__BUGO-G		__CUGO-G										
G	(209)	G	(209)	45	1-1/2 1-5/8 1-11/16 1-3/4	2-1/16 52.4	1-43/64 42.4	1-21/64 33.7	.10	2-1/2 63.5	2.061	.06
__BUHO-H		__CUHO-H										
H	(210)	H	(210)	50	1-11/16 1-3/4 1-13/16 1-7/8 1-15/16 2	2-5/16 58.8	1-43/64 42.4	1-27/64 36.1	.10	2-3/4 69.9	2.311	.08
__BUJO-I		__CUJO-I										
I	(211)	I	(211)	55	1-15/16 2 2-1/16 2-1/8 2-3/16 2-1/4	2-9/16 65.1	1-55/64 47.1	1-37/64 40.1	.10	2-7/8 73.0	2.561	.09
__BUJO-J		__CUJO-J										
J	(212)	J	(212)	60	2-3/16 2-1/4 2-5/16 2-3/8 2-7/16	2-3/4 69.9	2-3/32 53.3	1-61/64 49.5	.10	3.0 76.2	2.749	.12
__BUKO-K		__CUKO-K										
K	(214)	K	(214)	70	2-7/16 2-1/2 2-5/8 2-11/16 2-3/4	3-1/16 77.8	2-7/64 53.5	1-61/64 49.5	.10	3-1/2 88.9	3.061	.12
__BULO-L		__CULO-L										
L	(215)	L	(215)	75	2-11/16 2-3/4 2-13/16 2-7/8 2-15/16 3	3-3/8 85.8	2-7/64 53.6	2-7/64 53.5	.10	4 101.6	3.249	.13
__BUMO-M		__CUMO-M										
M	(216)	M	(216)	80	2-15/16 3 3-1/8 3-3/16	3-1/2 89.0	2-11/32 59.7	2-11/32 59.7	.10	4 101.6	3.499	.13

PLANE BEARING INSTALLATION ARBOR

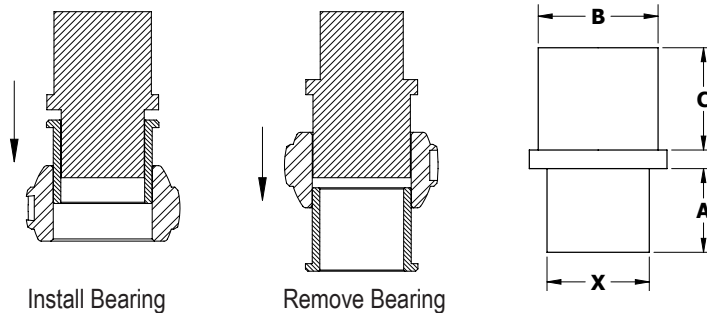

* Alphabetical shaft size indicates ID will accommodate locking sleeve. These are stocked arbors; other sizes available upon request.

STANDARD FLANGED BEARING		x= Shaft Diameter Range	A	B	C	Wt
Group	Ring		in mm	in mm	in mm	lbs
PATUAO-x	1/2 → 11/16	A*	3/4 19.1	63/64 25.0	13/16 20.6	.04
A (203)						
PATUBO-x	1/2 → 13/16	B*	13/16 20.6	1-1/8 28.6	15/16 23.8	.05
B (204)						
PATUCO-x	13/16 → 1	C*	29/32 23.0	1-19/64 32.9	1 25.4	.08
C (205)						
PATUDO-x	1 → 1-1/4	D*	1 25.4	1-35/64 39.3	1-3/16 30.2	.2
D (206)						
PATUEO-x	1-3/16 → 1-7/16	E*	1-1/8 28.6	1-47/64 44.1	1-23/64 34.5	.2
E (207)						
PATUFO-x	1-7/16 → 1-5/8	F*	1-5/16 33.3	1-29/32 48.4	1-1/2 38.1	.3
F (208)						
PATUGO-x	1-1/2 → 45mm	G*	1-9/32 32.5	2-3/64 52.0	1-35/64 39.3	.4
G (209)						
PATUHO-x	1-11/16 → 2	H*	1-3/8 34.9	2-19/64 58.3	1-35/64 39.3	.5
H (210)						
PATUIO-x	1-15/16 → 2-1/4	I*	1-35/64 39.3	2-35/64 64.7	1-3/4 44.5	.7
I (211)						
PATUJO-x	2-3/16 → 2-7/16	J*	1-29/32 48.4	2-47/64 69.4	2 50.8	.9
J (212)						
PATUKO-x	2-7/16 → 70mm	K*	1-29/32 48.4	3-3/64 77.4	2 50.8	1.0
K (214)						
PATULO-x	2-11/16 → 3	L*	2-1/16 52.5	3-1/4 82.5	2 50.8	1.2
L (215)						
PATUMO-x	2-3/4 → 3-3/16	M*	2-21/64 58.9	4 101.6	2-1/4 52.5	1.6
M (216)						

More About Locking Sleeves

Benefits of using Locking Sleeves with Plane Bearings

EDT stainless steel locking sleeves protect shaft surfaces from abrasion and the normal wear caused by plane bearings. Locking sleeves provide:

- Improved bearing surface to increase bearing life
- Contain lateral shaft movement (replaces standard locking collar)
- Protection to shaft
- Abrasion resistant
- Repair damaged shafting

Locking sleeves must run adjacent to polymer, not stainless steel. On Poly-Round® run on either side of the insert, depending on space available. On All-Round® run against polymer flange (see page F4, View A and View B).

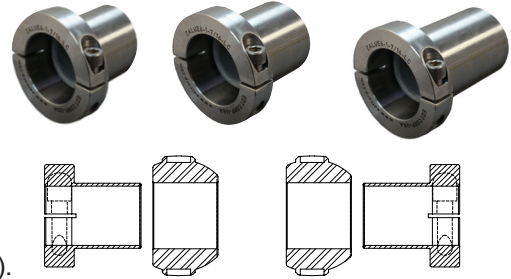

Comparison of setscrew locking sleeves and DoubleLock® sleeves

In some sizes, DoubleLock® sleeves have slightly wider collar than standard locking sleeves to accommodate hardware that is strong enough to draw the split flange together to properly secure around the shaft. For details on specific shaft sizes, refer to charts on pages F-10 and F-11.

Example: 1" locking sleeve dimensional change

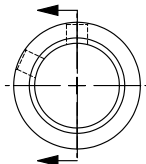
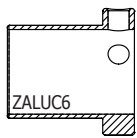

- Body length remains the same at 1.14"
- ZALUC6-1 has 1-1/2" collar OD x .375 width, overall length at 1.53"
- ZALUC6-1-LC has 1-3/4" collar OD x .50 width, overall length at 1.63"

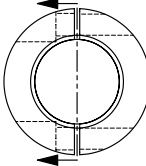
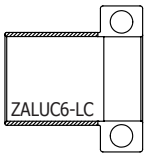

DoubleLock® is available in all sizes/styles of locking sleeves

- DoubleLock® ZALUC6-x-LC sleeve mates with standard Poly-Round®
- DoubleLock® ZAMUC6-x-LC sleeve mates with narrow Poly-Round®

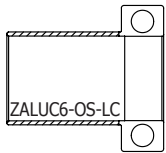

- DoubleLock® ZALUC6-x-OS-LC sleeve mates with symmetrical Oven Style Poly-Round® (-HTV fixed end)

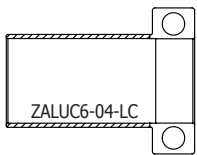

- DoubleLock® ZALUC6-x-04-LC sleeve mates with standard length Poly-Round® (-HTE expansion end)

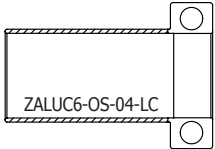

- DoubleLock® ZALUC6-x-OS-04-LC sleeve mates with symmetrical Oven Style Poly-Round® (-HTE expansion end)

Extra Advantages of DoubleLock® sleeves over setscrew locking sleeves

- Holds better under higher thrust loads
- Retains its position under temperature cycling

Recommended applications to definitely consider DoubleLock® sleeves

- Vertical shaft installation
- Ovens
- High load angled or vertical screw conveyor
- Freezers
- Other high thrust load drives